

7 Dimension Sheets for DR./DRL Series AC Motors/Brakemotors

7.1 Notes on the dimension sheets

Observe the following notes regarding dimension sheets for 4-pole DR AC (brake)motors:

- The collective term IV (= industrial plug connectors) in the dimension sheets includes the plug connectors AC., AS., AM., AB., AD. and AK..
- Leave a clearance of at least half the fan guard diameter to provide unhindered air access.
- For brakemotors, do not forget to add the space required for removing the fan guard (= fan guard diameter).
- Different positions are possible for the manual brake release, see following figure. The four positions 33°, 123°, 213° or 303° are basically possible.

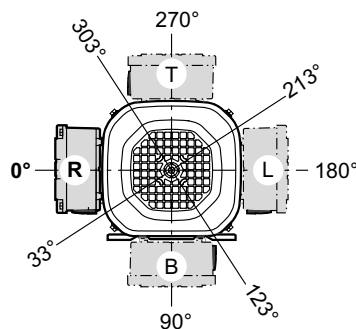

61011AXX

- The manual brake release is located at an angle of 303° to the terminal box as standard. If the position of the manual brake release is not specified, it rotates along with the terminal box. The manual brake release can be turned by $4 \times 90^\circ$. The forced cooling fan option (V) limits the possible positions of the manual brake release.

Brakemotors with forced cooling fan:

Motor sizes	Possible position of the manual brake release for terminal box position			
	0° (R)	90° (B)	180° (L)	270° (T)
71..BE../V	213°, 303°	33°, 303°	33°, 123°	123°, 213°
80..BE../V				
90..BE../V				
100..BE../V				
112..BE../V				
132..BE../V				
160..BE../V				
180..BE../V				
200..BE../V				
225..BE../V				
315..BE../V				



Software support

Not any cable entry position [X, 1, 2, 3] and terminal box position [0°(R), 90°(B), 180°(L), 270°(T)] can be chosen. Some additional features for the motor require a connection inside the terminal box, which means this terminal box is larger than the standard terminal box due to the normative air gaps and creepage distances. The dimension sheets only depict the standard terminal box.

For a thorough check of the possible positions of your drive, you can use the DRIVECAD software in DriveGate on the SEW-EURODRIVE website.

- If you are already a registered DriveGate user: <https://portal.drivegate.biz/drivecad>.
- If you are not yet a registered DriveGate user: www.sew-eurodrive.de → DriveGate login.

Tolerances

Shaft heights

The following tolerances apply to the indicated dimensions:

h	≤ 250 mm	→ -0.5 mm
h	> 250 mm	→ -1 mm

Shaft ends

Diameter tolerance:

∅	≤ 28 mm	→ ISO j6
∅	≤ 50 mm	→ ISO k6
∅	> 50 mm	→ ISO m6

Center bores according to DIN 332, shape DR:

∅ = 7 - 10 mm	→ M3	∅ > 30 - 38 mm	→ M12
∅ > 10 - 13 mm	→ M4	∅ > 38 - 50 mm	→ M16
∅ > 13 - 16 mm	→ M5	∅ > 50 - 85 mm	→ M20
∅ > 16 - 21 mm	→ M6	∅ > 85 - 130 mm	→ M24
∅ > 21 - 24 mm	→ M8	∅ > 130 mm	→ M30
∅ > 24 - 30 mm	→ M10		

Keys: according to DIN 6885 (domed type)

Flanges

Centering shoulder tolerance:

∅ ≤ 230 mm (flange sizes A120 – A300)	→ ISO j6
∅ > 230 mm (flange sizes A350 – A660)	→ ISO h6

Different flange dimensions are available for each AC (brake) motor size. The respective dimension drawings will show the flanges approved for each size.

Eyebolts, lifting eyes

Motors up to DR.100 are delivered without special transportation fixtures.

Motors ≥ DR.112 are equipped with removable lifting eye bolts.

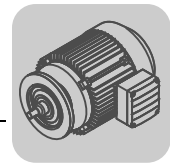

Motor dimensions

Additional motor features The motor dimensions may change when installing additional motor features. Refer to the dimension drawings of the additional motor features.

Special designs In case of special designs or comprehensive additional features connected in the terminal box, the terminal box dimensions might deviate from the standard.
Observe the notes in the order confirmation from SEW-EURODRIVE.

EN50347 European standard EN50347 became effective in August 2001. This standard adopts the dimension designations for three-phase AC motors for sizes 56 to 315M and flange sizes 65 to 740 from the IEC72-1 standard.
The new dimension designations according to EN50347/IEC72-1 are used for the relevant dimensions in the dimension sheet tables.

8/2 and 8/4-pole motors The pole-changing DRS motors with 8/2 or 8/4 poles have the same dimensions as the standard 4-pole DRS motor.

2 and 6-pole motors EN 50347 contains suggested dimensions based on the power rating and the number of poles. As a result of the new efficiency requirements for AC motors, these dimensions cannot always be complied with completely.
The 2- and 6-pole motors therefore might have different flange, foot or output shaft dimensions compared to EN 50347.
The tables on page 194 ff show the dimensions:

- The standard dimensions of the 4-pole motor are marked in bold.
- The gray fields show the suggested value of EN 50347.

Notes on the dimension sheets of the DRL motors

Special designs The DRL motor dimension sheets show the standard motors/brakemotors. For other designs, please refer to the dimension sheets of the DR. series AC (brake)motors on page 110 ff.